

araven

FOOD SAFETY INNOVATION



Contenedores GN 2/1
GN 2/1 Food Boxes · Bacs GN 2/1

Contenedores GN 2/1

GN 2/1 Food Boxes · Bacs GN 2/1



Óptima geometría. Base ondulada
Optimum shape. Curved drain base.
Géométrie optimum. Base ondulée

Doble posición de la cubeta. Posición encajable (A). Posición apilable sin tapa (B).
Two nesting options. Fully Nested. (A). Stacked without lid (B).
Double position du bac. Position emboîtable (A). Position empilable sans couvercle (B).



ColorClip: Código de color para evitar las contaminaciones cruzadas
ColorClip: Colour coding to avoid cross-contamination.
ColorClip: Code de couleur pour éviter les contaminations croisées



Sistemas de identificación del alimento integrados en las piezas.
Integrated food labeling system.
Systèmes d'identification de l'aliment intégrés aux articles.



Asa ergonómica y Resistente
Heavy duty, ergonomic handle
Anse ergonomique et Résistante

+80°C | +176°F
-40°C | -40°F
 ABS



2x
Ref. 74069 / 70L · 18Gal
650x530xh300 mm
25%⁸°x20%⁸°x12"

2x
Ref. 74070 / 90L · 23Gal
650x530xh400 mm
25%⁸°x20%⁸°x15"

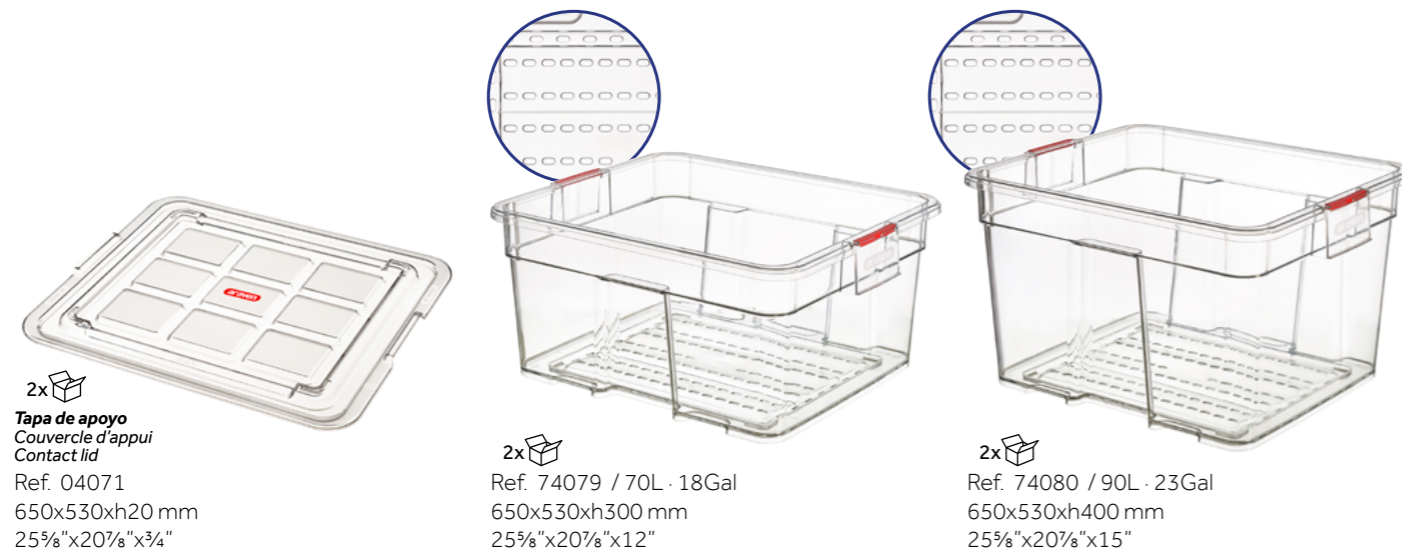

2x
Tapa de apoyo
Couvercle d'appui
Contact lid
Ref. 04071
650x530xh20 mm
25%⁸°x20%⁸°x³/₄"

2x
Ref. 74079 / 70L · 18Gal
650x530xh300 mm
25%⁸°x20%⁸°x12"

2x
Ref. 74080 / 90L · 23Gal
650x530xh400 mm
25%⁸°x20%⁸°x15"

+90°C | +194°F
-40°C | -40°F
 HDPE



2x
Ref. 04069 / 70L · 18Gal
650x530xh300 mm
25%⁸°x20%⁸°x12"

2x
Ref. 04070 / 90L · 23Gal
650x530xh400 mm
25%⁸°x20%⁸°x15"



2x
Tapa de apoyo
Couvercle d'appui
Contact lid
Ref. 04071
650x530xh20 mm
25%⁸°x20%⁸°x³/₄"

2x
Ref. 04079 / 70L · 18Gal
650x530xh300 mm
25%⁸°x20%⁸°x12"

2x
Ref. 04080 / 90L · 23Gal
650x530xh400 mm
25%⁸°x20%⁸°x15"

Sistema de descongelación · Defrost system · Système de décongélation

La base ondulada está especialmente diseñada para que exista la menor zona de contacto con el alimento. Los alimentos se colocarán en el interior de cubetas perforada encajada sobre la otra cubeta que recogerá el líquido que desprenda evitando que goteen y contaminen otros alimentos cercanos.

The curved drain base has been specially designed to minimize contact with food and aid air circulation. The perforated box nested into the food box will provide drainage, separate any residue liquid and prevent cross contamination.

La base ondulada está especialmente diseñada para que exista la menor zona de contacto con el alimento. Los alimentos se colocarán en el interior de cubetas perforada encajada sobre la otra cubeta que recogerá el líquido que desprenda evitando que goteen y contaminen otros alimentos cercanos.

Posición encajable

Fully Nested · Position emboitable



17L · 4Gal
GN 2/1 · h300mm · h12"



17L · 4Gal
GN 2/1 · h400mm · h15"

Posición apilable sin tapa

Stacked without lid · Position empilable sans couvercle



49L · 12Gal
GN 2/1 · h300mm · h12"



68L · 17Gal
GN 2/1 · h400mm · h15"

Carga recomendada · Recommended weight load · Charge recommandée

GN 2/1 · h300mm 12"

70kg x 4 (1+3cubetas)
154lb x 4 (1+3 food boxes) = 616lb
70Kg x 4 (1+3 bacs)

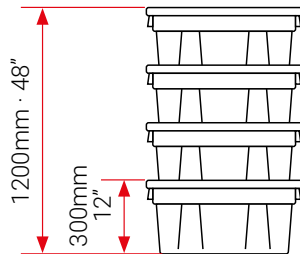

GN 2/1 · h400mm 15"

90kg x 4 (1+3cubetas)
198lb x 4 (1+3 food boxes) = 792lb
90Kg x 4 (1+3 bacs)

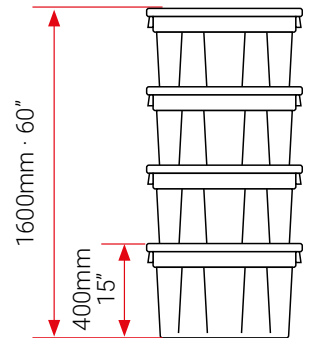

Plataforma con ruedas GN 2/1

GN 2/1 Dolly Trolley Platform
Plate-forme sur roulettes GN 2/1



1x
Ref. 61223
580x490xh140mm · 22⁷/₈"x19¹/₄"x5¹/₂"
INT: 550xh471mm · 21⁵/₈"x18¹/₂"



Ø75mm
Rueda de goma
Castors with rubber tyres
Pneu de caoutchouc gris



Carga máxima recomendada · x 2 cubetas GN 2/1
Maximum recommended weight load · x 2 food boxes GN 2/1
Charge maximale recommandée · x 2 bacs GN 2/1